

SUPERMASTER

ATTUATORE ELETTRICO A CATENA – FORZA 400 N – CORSA 450 – 600 - 800 mm

ELECTRIC CHAIN ACTUATOR – FORCE 400 N – STROKE 450 – 600 - 800 mm

BOITIER A CHAÎNE ELECTRIQUE – FORCE 400 N – COURSE 450 – 600 - 800 mm

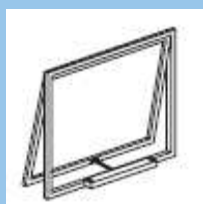

SPORGERE
TOP HINGED WINDOW
CHÂSSIS PROJÉTANT

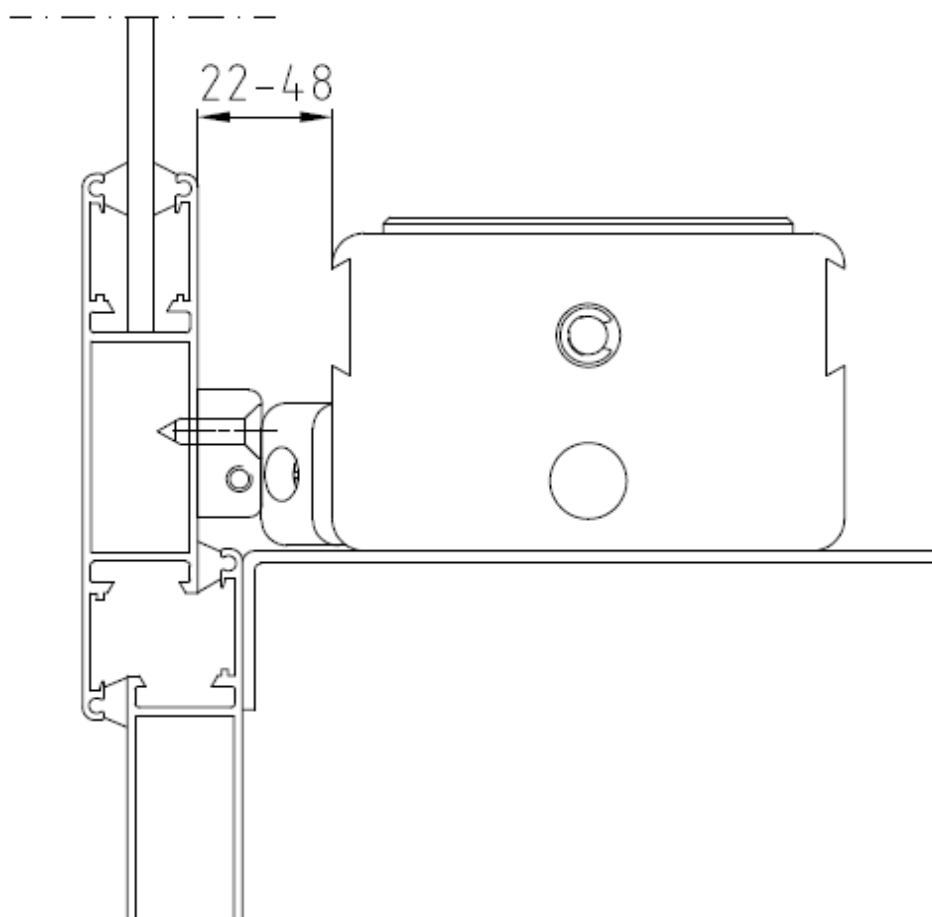

- I** Applicazione con davanzale senza staffe aggiuntive
- GB** On windows with windowsill without brackets
- F** Sur appui sans étriers additionnels

SUPERMASTER

ATTUATORE ELETTRICO A CATENA – FORZA 400 N – CORSA 450 – 600 - 800 mm

ELECTRIC CHAIN ACTUATOR – FORCE 400 N – STROKE 450 – 600 - 800 mm

BOITIER A CHAÎNE ELECTRIQUE – FORCE 400 N – COURSE 450 – 600 - 800 mm

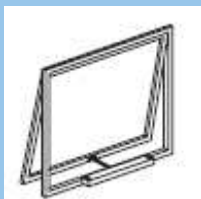

SPORGERE
TOP HINGED WINDOW
CHÂSSIS PROJETANT

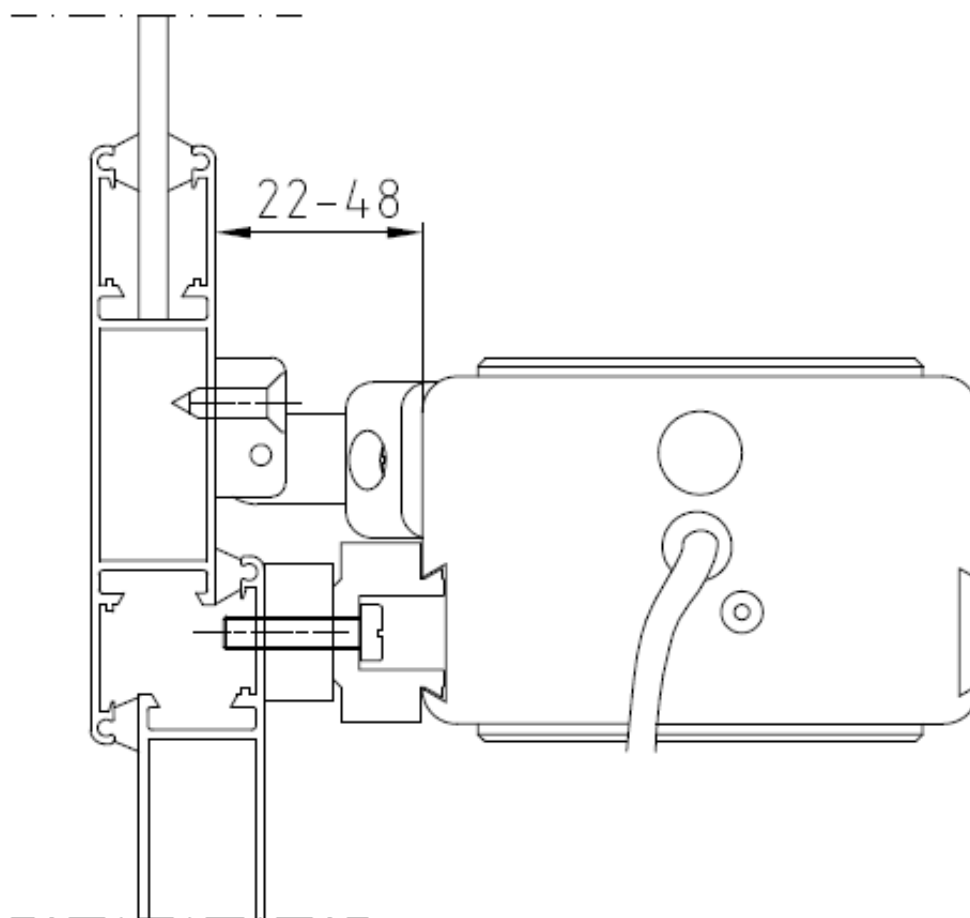

- I** Applicazione senza davanzale con staffa
- GB** Without windowsill with bracket
- F** Sans appui avec étrier

SUPERMASTER

ATTUATORE ELETTRICO A CATENA – FORZA 400 N – CORSA 450 – 600 - 800 mm

ELECTRIC CHAIN ACTUATOR – FORCE 400 N – STROKE 450 – 600 - 800 mm

BOITIER A CHAÎNE ELECTRIQUE – FORCE 400 N – COURSE 450 – 600 - 800 mm

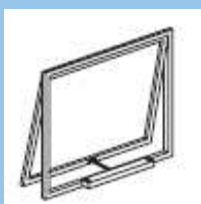

SPORGERE
TOP HINGED WINDOW
CHÂSSIS PROJETANT

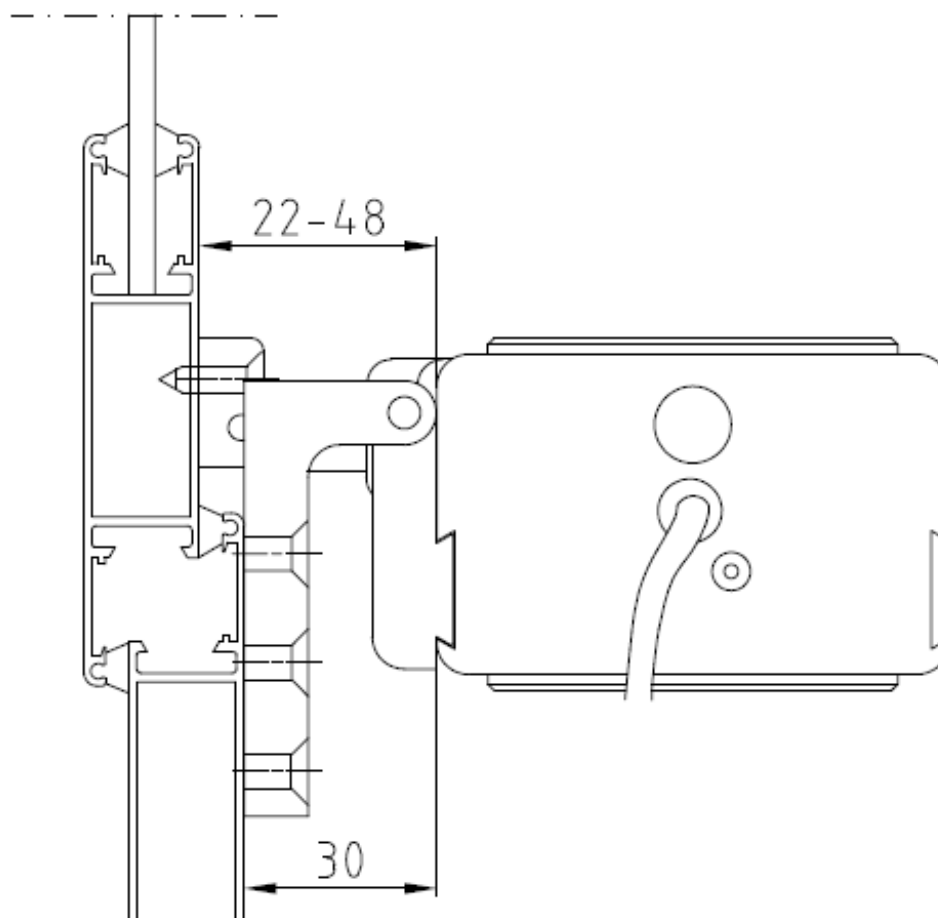

- I** Applicazione a telaio con kit oscillante
- GB** On the frame with pivoting brackets
- F** Sur dormant avec kit étriers pivotants

SUPERMASTER

ATTUATORE ELETTRICO A CATENA – FORZA 400 N – CORSA 450 – 600 - 800 mm

ELECTRIC CHAIN ACTUATOR – FORCE 400 N – STROKE 450 – 600 - 800 mm

BOITIER A CHAÎNE ELECTRIQUE – FORCE 400 N – COURSE 450 – 600 - 800 mm

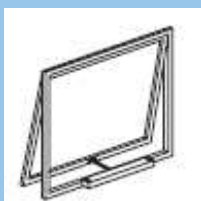

SPORGERE

TOP HINGED WINDOW

CHÂSSIS PROJETANT

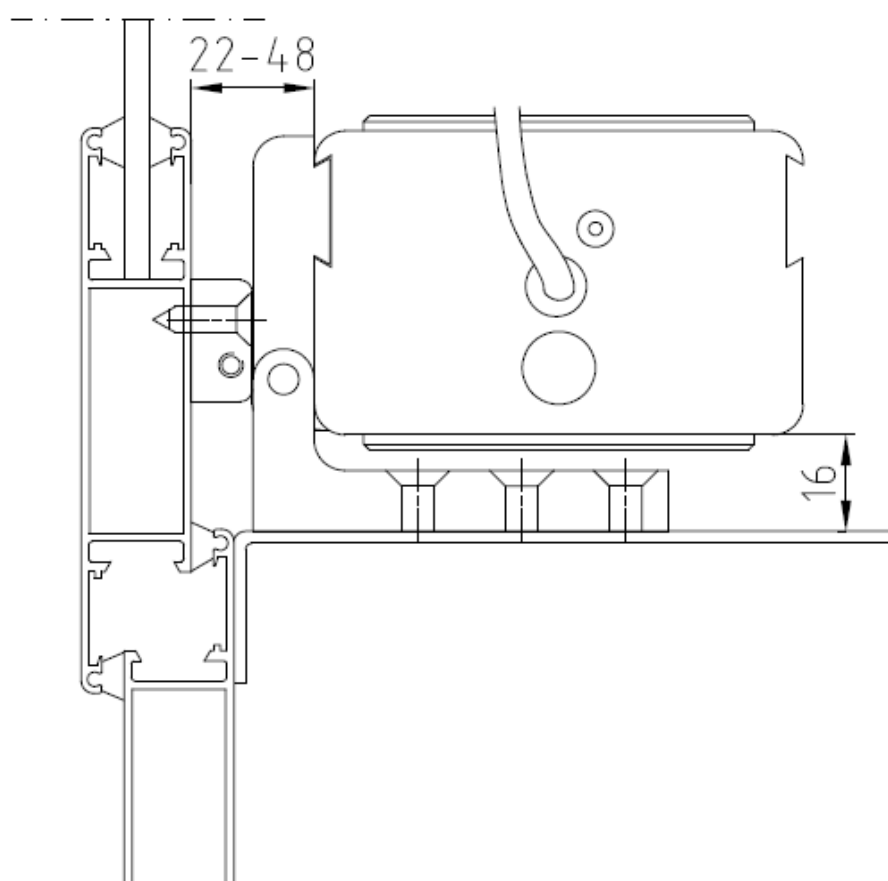

I Applicazione a davanzale con kit oscillante

GB On windows with windowsill with pivoting brackets

F Sur appui avec kit étriers pivotants

SUPERMASTER

ATTUATORE ELETTRICO A CATENA – FORZA 400 N – CORSA 450 – 600 - 800 mm

ELECTRIC CHAIN ACTUATOR – FORCE 400 N – STROKE 450 – 600 - 800 mm

BOITIER A CHAÎNE ELECTRIQUE – FORCE 400 N – COURSE 450 – 600 - 800 mm



VASISTAS
BOTTOM HINGED WINDOW
CHÂSSIS SOUFFLET

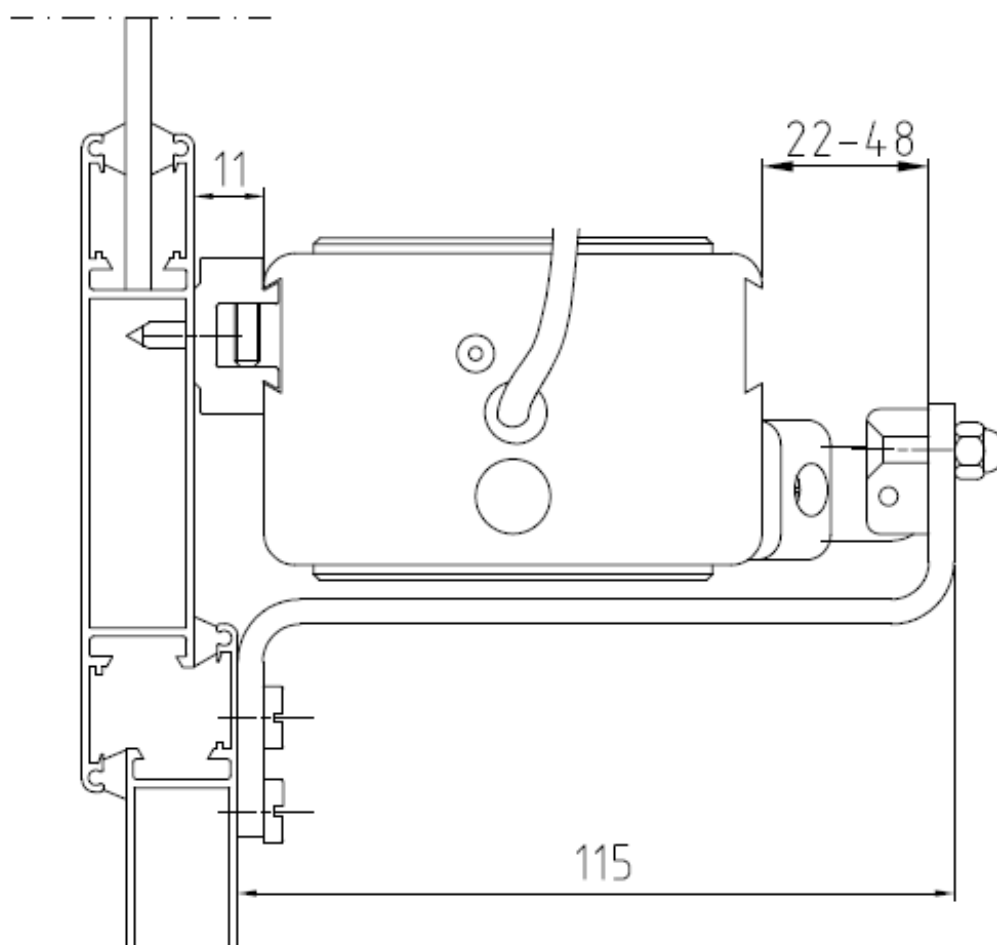

- I** Applicazione a telaio con staffa vasistas
- GB** On the frame with bracket or bottom hinged window
- F** Sur dormant avec étrier pour fenêtre à soufflet

SUPERMASTER

ATTUATORE ELETTRICO A CATENA – FORZA 400 N – CORSA 450 – 600 - 800 mm

ELECTRIC CHAIN ACTUATOR – FORCE 400 N – STROKE 450 – 600 - 800 mm

BOITIER A CHAÎNE ELECTRIQUE – FORCE 400 N – COURSE 450 – 600 - 800 mm

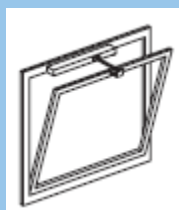

VASISTAS
BOTTOM HINGED WINDOW
CHÂSSIS SOUFFLET

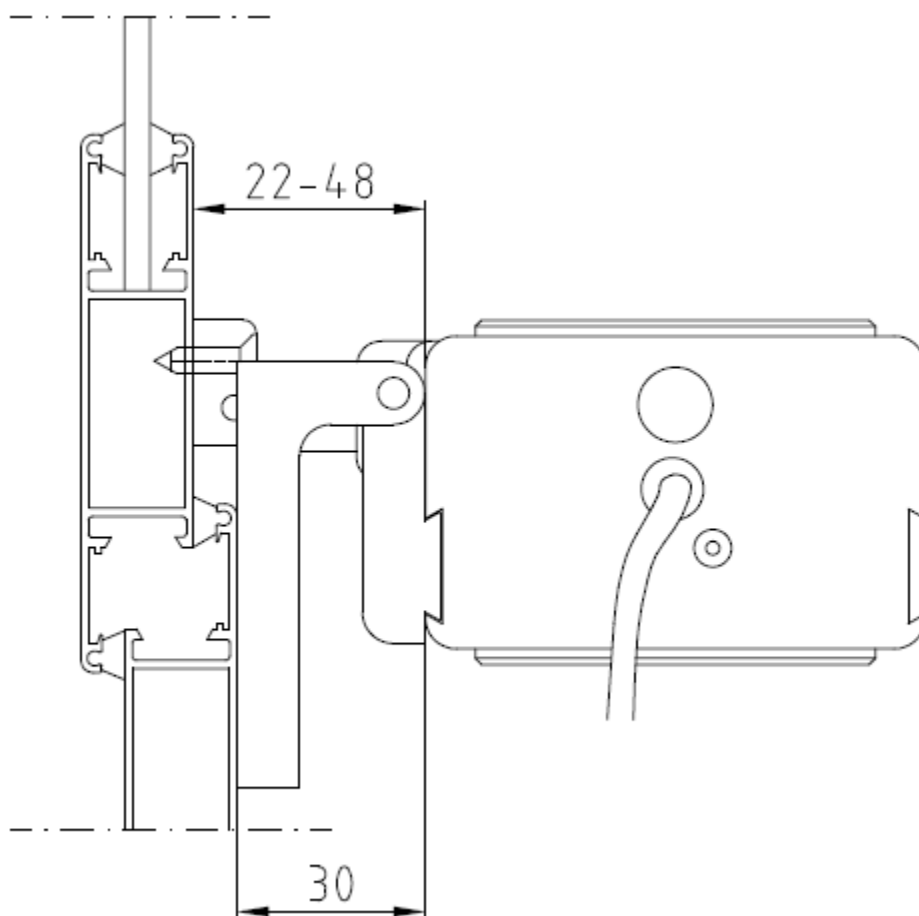

- I** Applicazione ad anta con kit oscillante
- GB** On the vent with the pivoting bracket
- F** Sur ouvrant avec kit étriers pivotants

SUPERMASTER

ATTUATORE ELETTRICO A CATENA – FORZA 400 N – CORSA 450 – 600 - 800 mm
ELECTRIC CHAIN ACTUATOR – FORCE 400 N – STROKE 450 – 600 - 800 mm
BOITIER A CHAÎNE ELECTRIQUE – FORCE 400 N – COURSE 450 – 600 - 800 mm



VASISTAS
BOTTOM HINGED WINDOW
CHÂSSIS SOUFFLET

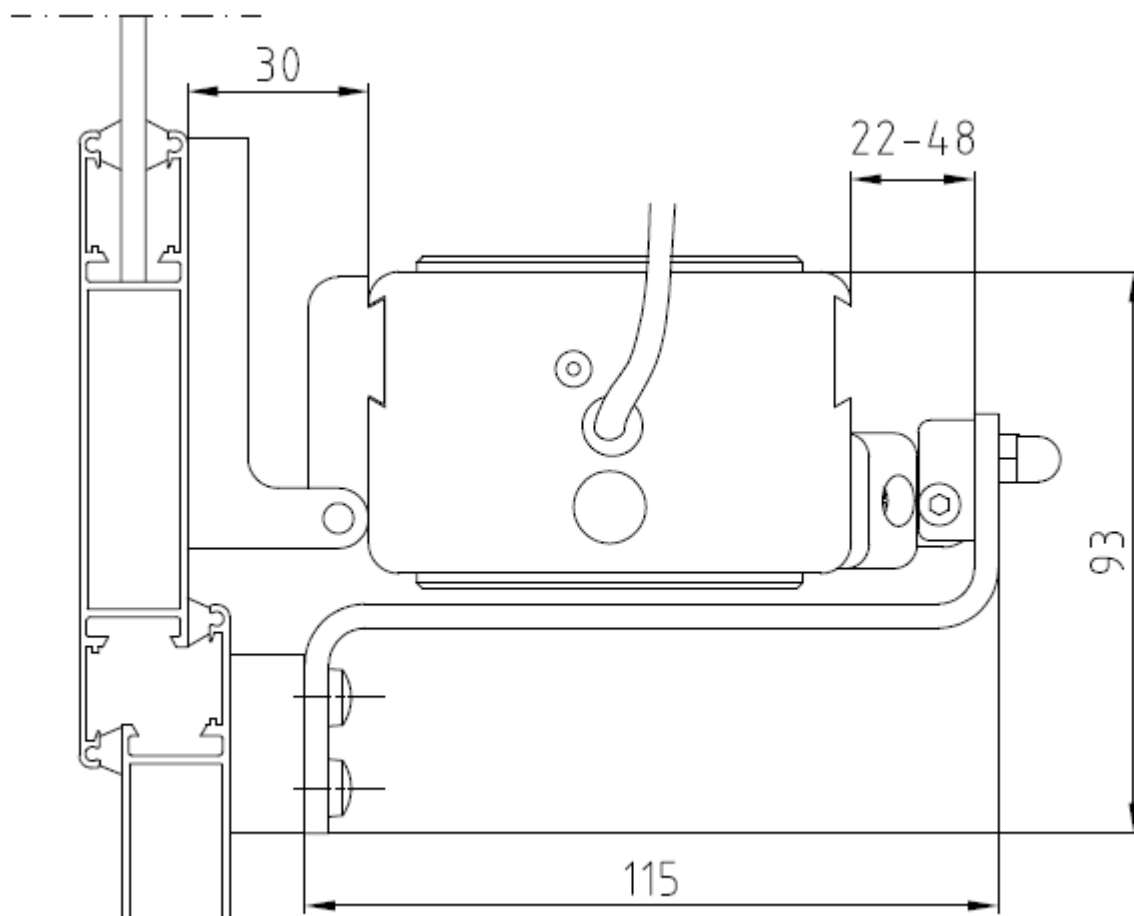

- I** Applicazione a telaio con kit oscillante e staffa
- GB** On the frame with the pivoting bracket and bracket
- F** Sur dormant avec kit étriers pivotants et étrier